

CHECK WEIGHER CW 1200 GX & STANDARD MODEL

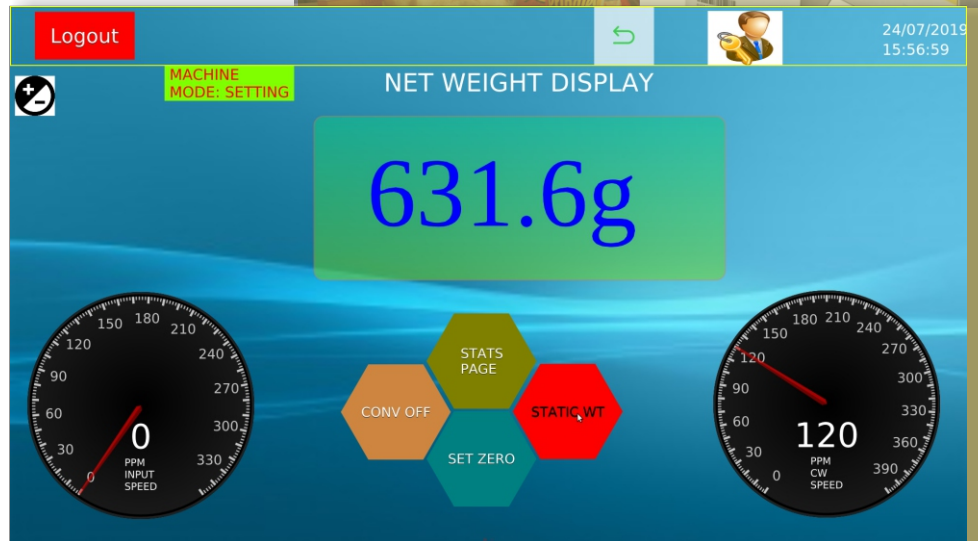

GX SERIES

- 10" LCD touch screen
- Modern Graphical User Interface
- FDA 21 CFR Part 11 - compliant
- Over 5 years of data storage
- Informative dashboard
- Multilevel user ID
- Multi-weight classification
- Inbuilt report generation
- Ethernet Connectivity
- 1000 products memory

STANDARD MODEL

- 7" Display
- 200 Products memory
- 3 level user ID
- Statistical data
- Printer interface

Cw1200 (Standard/GX series) model ensure precise weight check of every product, the high accuracy and maximum throughput. Easy to use with intuitive colour touchscreen and icon-driven menus for fast product set up. The system is designed for easy removal for cleaning purpose.

SALIENT FEATURES - STANDARD AND GX SERIES MODELS

- Height Adjustment for Ease of Integration with Existing Lines
- Auto adjustment of conveyor speed according to throughput PPM
- Facility for Dynamic Weight Compensation
- Display of Net Weight
- Statistical Data of Total Accept, Total Reject, Standard Deviation
- Interlock with other machines
- Tendency control (optional)
- Various infeed mechanism like bottle separator, stabilizer, turn table etc. available

GENERAL SPECIFICATION

- **Model:** CW 1200 STD / GX
- **Speed:** 120-150 / 400 PPM
- **Weighing Range:** 2gm to 1kg
- **Belt Height from Floor:** 720mm + 100mm (can be customized)
- **Weighing Conveyor Platform:** 350mm Long, 250mm Wide
- **Conveyor Belt:** 180mm (width)
- **Overall System Length:** Approx - 1320mm
- **Weighing Sensor:** Load Cell / Weigh Cell
- **Resolution:** 0.1gm
- **Display:** 7" / 10" LCD screen
- **Power Requirement:** Single Phase 230 V AC / 50HZ / 300VA
- **Rejection mechanism:** Air blow / Pusher / Diverter
- **Pneumatic Requirement:** 6Kgs / cm² for all rejection mechanisms

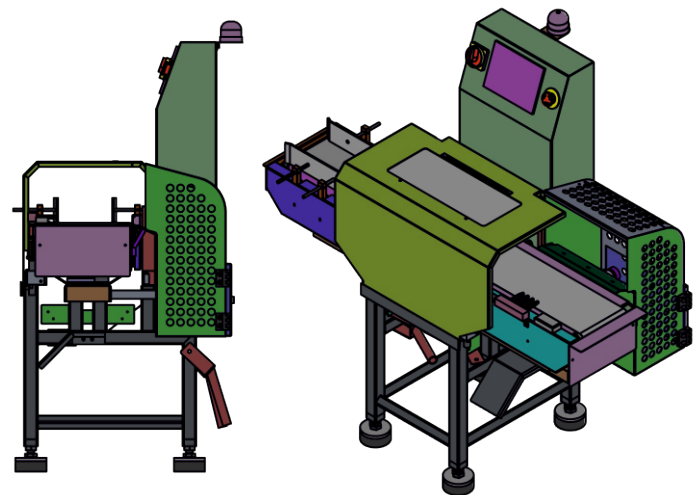
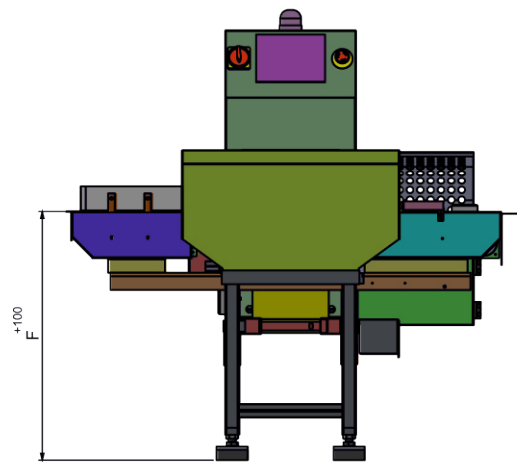
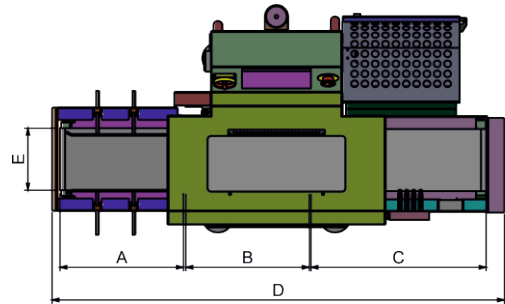

	A	B	C	D	E	F
CW1200	350	350	500	1320	180	720



TECHNOFOUR ELECTRONICS PVT. LTD.

Marketed By

PT. AIRLOCK INDONESIA JAYA RAYA

Kawasan Industri Jababeka Tahap VI

Jl. East Park Boulevard Block C1B No. 7

Jatireja - Cikarang Timur, Bekasi

ZIP 17530, Indonesia

T. +62 21 8932 1222

F. +62 21 8932 1555

E. sales@airlockintl.co.id

W. www.airlockintl.co.id

* Due to continuous development, specifications subject to change without notice.